

## SAFETY - INSTALLATION - OPERATING AND MAINTENANCE INSTRUCTIONS

# INDUSTRIAL CENTRIFUGAL FANS

This Manual is for the following Fans: D/10A and D/36A (SQA/SQB, SQAD/SQBD), Centrifugal Airfoil and "B" Wheel Fans; D/16A, D/39A (SQI), and D/52 Industrial Fans; D/44 Plug Fans; D/51 Double Width, Single Width and Plenum Fans; D/53 Pressure Blowers, D/5120 Plenum Fans; D/64 PBI (Packaged Backward Inclined); D/70 Plug Fan.



D/36A Centrifugal Fan



D/53 Pressure Blower



D/16A Industrial Fan



D/70 Plug Fan



D/51 Double Width Fan



D/64 PBI

### TO ORDER SPARE PARTS:

Spare or repair parts may be ordered from your nearest "Chicago" Sales Engineer by giving the part name, (Wheel, Motor, Bearing, etc.) and the FAN SERIAL NUMBER taken from the nameplate or the JOB ORDER drawings. If possible also give the bearing or shaft size and the fan class. Due to the small number of parts required, spare parts lists are neither necessary nor available. Use these instructions instead.

## RECEIVING:

Chicago Blower Corporation equipment is prepared for shipment in accordance with the Uniform Freight Classification. It is thoroughly inspected at the factory and, barring damage in transit, should be in good condition upon arrival.

When a carrier signs Chicago Blower Corporation's bill of lading, the **carrier accepts the responsibility** for any subsequent shortages or damage evident or concealed, and **any claim must be made against the carrier by the purchaser**. Evident shortage or **damage should be noted on the carrier's delivery document** before signature of acceptance. Inspection by the carrier of damage evident or concealed must be requested. After inspection, issue a purchase order for necessary parts or arrange for return of the equipment to Chicago Blower Corporation factory for repair.

Chicago Blower fans are shipped, skidded, and may be handled and moved using good rigging techniques, being careful to avoid concentrated stresses that distort any of the parts.

## STORAGE:

If the fan installation is to be delayed, store the unit in a dry, protected area. Protect the fan, especially fan and motor bearings, from moisture and vibration. Protect all machined surfaces such as shafts, couplings, and bushings. Rotate the wheel several revolutions every two weeks, stopping the wheel in a position other than its initial position. Keep the bearings fully greased by filling monthly with a grease compatible to that

originally supplied. Contact Chicago Blower for extended storage instructions.

## SAFETY PRECAUTIONS:

The fan which you have purchased is a rotating piece of equipment and can become a source of danger to life or cause injury if not properly applied. The **maximum operating temperature** or **speed** for which this fan is designed **must not be exceeded**. These limits are given in our catalog or on Chicago Blower Corporation drawings.

Personnel who will operate this fan, or those who will perform maintenance thereon, **must be given this bulletin to read and warned of the potential hazards of this equipment**.

This pamphlet contains general recommendations, but specific requirements may apply to the individual installation. Such requirements are outlined in federal, state and local safety codes. Strict compliance with these codes, and strict adherence to these installation instructions are **the responsibility of the user**.

## INSTALLATION:

1. Good results **require a proper foundation**. Foundations should be level, rigid, and of sufficient mass for the equipment. Concrete is preferable. Its mass should be at least four times the fan weight. Adequately brace steel platforms in all directions. The minimum natural frequency of any part must be at least 50% higher than the fan running speed.

## Instructions for Plug Fans

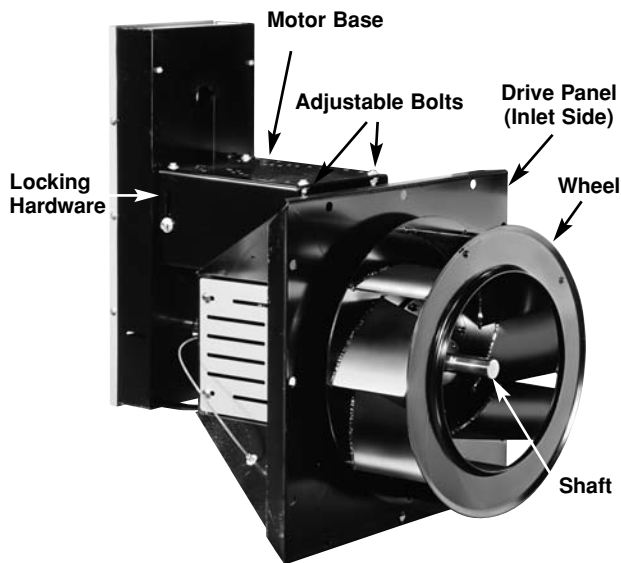

## INSTALLATION:

1. Inspect the equipment for correctness and condition. If any discrepancies are found, contact your local Chicago Blower Corporation representative immediately for assistance.
2. The fan wheel assembly has been dynamically balanced for vibration-free operation. Any damage or rough handling may destroy this balance and require rebalancing. Take care to prevent damage to the wheel hub finished bore. Protect the fan shaft from marks, gouges, nicks or bending.
3. The fan bearings have been factory lubricated and are shipped in cartons to protect them. Do not remove the bearings from the cartons until ready for assembly.

## ASSEMBLY PROCEDURE:

1. Drive panel must be mounted on a rigid and substantial foundation on the plenum chamber wall. Careful design of the mounting structure is needed to insure vibration-free operation. If the structure is not rigid, harmonic vibrations occur. On some "soft" structures, field touch-up balancing may be necessary to **balance the complete system structure**.
2. Make sure the wheel rotation is correct (**clockwise or counterclockwise as viewed from the drive side**) for the planned discharge from the plenum chamber or accessory housing.
3. If the accessory housing is being used, it should be installed flush against the inside plenum wall before the wheel is put on the fan shaft. Fasten to the plenum wall by bolting or stitch welding.
4. Check shaft and keyways for nicks from handling. File off. Slide the wheel onto shaft end with the longest keyway. Insert the key and lightly tighten the wheel set screws with the wheel positioned half way along the keyway.

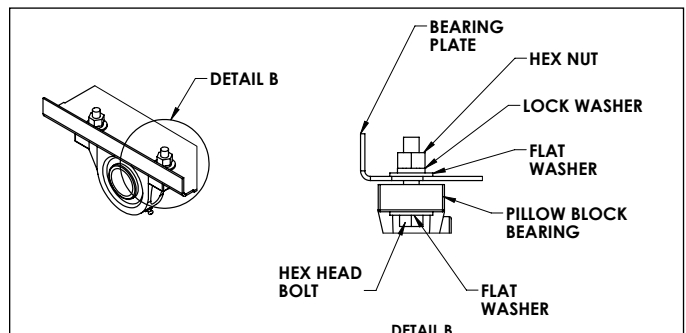
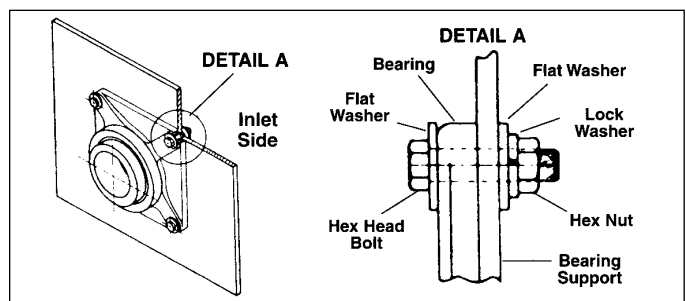

2. Shim the fan support points before tightening foundation bolts. Do not distort or twist the equipment. Duct connections should be smooth and straight. Elbows and other transitions should be located at least five wheel diameters from fan inlet and outlet (see AMCA Publication 201 for further details). **Flexible connections** should be used at inlet and discharge. The **fan should never support or restrain** any duct weight or force.
3. Make sure the power is locked "OFF".
4. Check wheel-to-inlet clearance to make sure it has not shifted during shipment or handling. There should be approximately equal radial clearance all around. Rotate wheel by hand to check that it runs free.
5. If the wheel is striking, correct it by loosening the hub set screws and reposition the wheel on the shaft, or loosen the motor mounting bolts (for Arrangement 4 fans) and realign the wheel to the inlet so it does not hit. Retighten all set screws and bolts and turn by hand again.
6. If the fan wheel is fastened with a taper-lock bushing and the wheel must be shifted, follow this procedure:
  - a. Match mark the bushings and the hub so they can be reinstalled in exactly the same relative position so as to not unbalance the wheel.
  - b. Remove all bolts from the bushings.
  - c. Insert two bolts in the threaded holes in the bushing. (Note that one bolt is left over and not used in the demounting.)
  - d. Tighten bolts alternately until bushing is loosened in hub. If bushing does not loosen immediately, lightly tap hub while applying torque to the bolts.

To reinstall the taper-lock bushing in the wheel hub, position the bushing to align the match marks and insert the three mounting bolts through the unthreaded bushing holes into the hub. Alternately tighten the bolts. When tightening, the bolts should be turned down equally to the initial Torque requirement given below. Then tighten the bolts progressively one-half turn per bolt to the Second Torque setting. Finally, the bolts should be tightened in small increments to the Final Torque settings.

Size Bushing	Initial Torque*		Second Torque*		Final Torque*	
	Alum.	Steel.	Alum.	Steel.	Alum.	Steel.
Q & R	57	120	108	240	228	348
P	36	84	72	132	132	192

\*Torque values shown are inch lbs. and apply when both components are either aluminum or steel. If either component is aluminum, use values for aluminum. Values for steel are for Grade 5 hardware.

Check bushing to verify type or refer to bushing box sent with the fan.

5. From inside the plenum, push the drive end of the drive shaft through the plenum shaft hole and through the inboard bearing bracket. With the shaft end halfway to the outboard bracket, slip one bearing on the shaft. Then push the wheel-shaft assembly all the way through and install the drive bearing. Use mounting hardware as shown below. Both bearings are the same
6. With the wheel temporarily pushed flush against the inside plenum wall, the shaft can be centered on the hole, the inboard bearing mounting bolts tightened and then the outboard bearing mounting bolts tightened. This locates the shaft perpendicular to the plenum wall and fan drive panel. Check level shaft.
 

If the fan is vertically mounted with inlet down, block the wheel and shaft in place with wood blocking to prevent damage. Do not block bearings to shaft yet.
7. Slide the shaft through the bearings and locate its drive end flush with the end of the motor shaft. Make sure the bearing locking collar is in position and tighten set screws to the bearing manufacturer's torque levels. See bearing manufacturer's instructions enclosed for details.
8. Slide the wheel along the shaft and position it a distance from the plenum wall, determined by the thickness of the insulation or the gap designed in the plenum. This dimension is not critical. Any extra length of shaft may extend through the hub without harm.
9. Install the inlet cone loosely on the housing or plenum structure, attaching it only at four points until final adjustments are made. Move the wheel along the shaft so that it slightly overlaps the inlet cone. Position the inlet cone to be concentric to the wheel opening with equal spacing in a radial direction all around. The inlet cone can be firmly fastened at this time.

On a Heat Fan or a fan **not** operating at maximum static pressure, it is satisfactory to have an axial gap between the wheel and inlet cone of 3/16" to 5/8" depending upon the fan size. This axial gap can be adjusted by moving the wheel closer to or farther away from the cone. **Tighten wheel set screws.**

Recheck the wheel cone to inlet cone clearance.

10. Mount the adjustable motor base on the drive panel gusset as shown in the illustration. Mount the motor on the adjustable motor base and adjust the base height for the approximate center distance of the V-belt being used.

7. Check the motor wiring and fusing in accordance with the National Electrical Code and local requirements. Follow wiring diagram on the motor nameplates.
8. Chicago Blower requires that all appurtenances, including ductwork or stacks, which are attached to the fan inlet or outlet, be independently supported, unless prior approval has been obtained from Chicago Blower. Excess dead loads or wind loads can distort the fan housing causing misalignment and possible failure. Flexible connections are also necessary to prevent duct expansion or movement from adding loads to the fan.

- 11 Loosely install the fan and motor sheaves and the belts. Tighten the fan sheave first, then align the motor sheave to the fan sheave. The fan and motor shafts must be parallel. See V-belt Drive section of this manual for sheave alignment and installation.

- 12.If the fan handles air above 300° F, install the shaft-cooling wheel by centering it in the space between the inboard bearing and drive panel. Two self-tapping bolts clamp the cooler to the shaft.

- 13.Install all shaft, cooling wheel, bearing guards and belt guards as required.

- 14.If the fan has been provided with an Inlet Volume Control (IVC), it is mounted in the inlet cone and no further adjustments are required except to hook up the operating lever to the Customer's Control.

The IVC should be checked for correct rotation. Looking at the IVC from the inlet side with IVC blades half closed, the blades should pre-spin the entering air in the same direction as the fan wheel is rotating.

**NOTE: For High Temperature Applications – The fan should not be shut off until the airstream temperature is below 150°.**

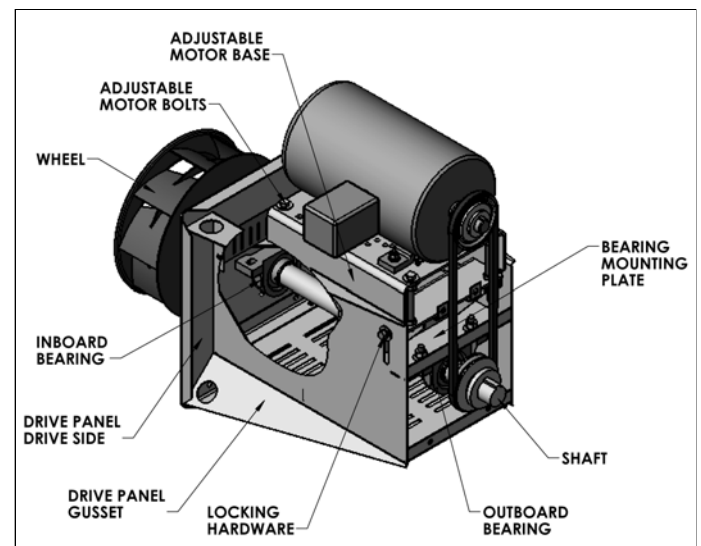

## FAN BEARINGS:

1. Lubricate fan bearings per bearing manufacturer's instructions in the packet attached to the fan. The fan is shipped with premium quality lithium based NLGI #2 grade grease. Continue to use NLGI #2 unless the bearing manufacturer's instructions specify a different type of grease for your application. Lubricate bearings immediately upon receipt. Add enough grease to cause slight purge at seals. It is common for bearings to purge excessive grease during first 24 to 48 hours of operation. See bearing manufacturer's instructions enclosed for lubrication schedule.
2. Bearing must be properly locked to the shaft. Check before operation. Make sure bearing locking collar is in position and set screws are tightened to the bearing manufacturer's recommended torque levels. See bearing manufacturer's instructions enclosed for details. The bearing set screws should be re-torqued after eight and twenty-four hours of operation.

## VERTICAL OPERATION:

If the fan is to operate with its shaft vertical, reset the bearings as follows

- a. With the shaft vertical, unlock the drive end bearing set screws and turn the shaft by hand. This allows the wheel end bearing to take the gravity load of the shaft and wheel.
- b. Re-lock the drive end bearing locking device and replace and torque set screws as required by the bearing manufacturer's instructions so that this bearing now takes only the belt pull.

## FANS WITH COUPLINGS:

On any completely assembled fan, where CBC has mounted the motor and coupling, it is required that the alignment be rechecked after the fan is set on its permanent foundation. It is not possible to hold alignment during shipment or when set on a different foundation. Coupling must be realigned and lubricated per manufacturer's instructions sent with the fan.

## V-BELT DRIVES:

1. Alignment of the drives must be checked with a straightedge or string. Belt tension must be properly adjusted to assure good belt and bearing life. Sheave faces should be parallel and aligned within 1/16". **Use balanced sheaves.**
2. With all belts in their proper grooves, adjust the centers to take up all slack and until the belts are fairly taut.
3. It is normal on v-belt drives handling more than 20 HP to "squeal" on start-up. **Do not tighten belts too tight.** Normal belt tension can be determined by being able to depress belt, at mid-point a distance equal to one belt width, with normal finger pressure.
4. After a few days operation the belts will seat themselves in the sheave grooves and it may become necessary to readjust so that the drive again shows a slight "bow" in the slack side. The drive is now properly tensioned and should operate satisfactorily with only an occasional readjustment to compensate for belt and groove wear.

## OPERATION OF FAN:

After installing the fan per these instructions and the instructions of the manufacturers, make final safety checks to prevent injury to personnel or damage to the equipment. **Always block rotating parts to prevent windmilling while inspecting the fan.**

1. Lock power source in "OFF" position.
2. Check bearings for alignment and proper lubrication, with wheel and inside of the housing clean and free of debris.
3. Check wheel position for proper clearance and rotation. Unblock rotating parts and turn wheel by hand to insure that it rotates freely.
4. Check sheave set screws or bushings and wheel set screws for tightness. If fan is a HEAT FAN, check to see that the shaft cooling wheel bolts are tight. Check foundation bolts. Secure safety guards and access doors.
5. If fan is designed for low density (such as high temp), make sure overload of fan motor is avoided if fan is run with standard air.

6. Start fan and allow unit to reach full speed, then shut down. During this short period, check for rotation, excessive vibration, any unusual noise, or overheating of the motor. Check the motor amps drawn against the nameplate rating. A plate over the fan inlet will limit the horsepower drawn during a test run with limited ductwork.

7. After the trial run lock the power "OFF".

8. Recheck for tightness of hold-down bolts, wheel set screws and keys, and retighten if necessary. Recheck after eight and twenty-four hours of operation.

9. The run-in period should be at least eight hours. Check bearings a minimum of once each hour during this period. Overgreasing may cause bearings to heat up. There need be no concern if the bare hand can be held on the bearings briefly. Bearings will vent extra grease and cool down after start-up. Recheck torque of all bearing set screws after eight and twenty-four hours of operation to insure levels are maintained per the bearing manufacturer's recommended levels.

10. Take vibration readings at the bearings, or the motor bearings if the fan wheel is mounted directly on the motor shaft. Adhere to these limits. Velocity limits in inches/second – Normal: 0.15; Alarm: 0.22; Shutdown: 0.50

## MAINTENANCE:

To insure long life and trouble-free service, frequently check all bearing lubrication. See the bearing manufacturer's instructions packed with the fan. Should excessive vibration develop, check the following possibilities:

1. Build-up of dirt or foreign material on the wheel.
2. Loose bolts on bearings, housings, foundation and drive.
3. V-belt drive improperly aligned. Belts must have proper tension, sheaves must be balanced.
4. Check wheel set screws.
5. Foreign matter may have entered fan causing damage to wheel, shaft or bearings.
6. Vibration may be coming from a source other than the fan. Stop the fan and determine if the vibration still exists. Disconnect the driver from the fan and operate it by itself to determine if it produces vibration.
7. Proper clearance between the wheel and the inlet.

A preventive maintenance schedule is a necessity for extending fan life. Establish a lubrication schedule based on time periods suggested in lubrication instructions and by motor and bearing manufacturers.

After approximately one (1) month of operation, all base, hub bearing, pedestal, etc. bolts should be checked.

Potentially damaging conditions are often signaled in advance by change in vibration and sound. A simple, regular audio-visual inspection of fan operation leads to correction of the condition before expensive damage occurs. Vibration levels should be checked by an approved technician using electronic balancing equipment.

If air handled by the fan contains corrosive, erosive or sticky materials, fan should be shut down regularly for inspection, cleaning and reconditioning of interior parts.

If the fan is to remain idle for an extended period, fill bearing with grease. Protect motor and exposed surfaces. Follow the motor manufacturer's recommendations for storage and rotate the shaft by hand several revolutions each month.

**Mechanical Integrity:** Certain operating conditions reduce the built-in strength in the fan impeller and may cause unsafe operation. It is the user's responsibility to inspect for these conditions as frequently as necessary and make corrections as required. Failure to comply with the following limits voids the Chicago Blower Corporation warrant.

**Maximum Safe Speed and Temperature:** Operation exceeding maximum safe RPM and temperature even for a short time causes overstressing or fatigue cracking of the impeller resulting in unsafe condition. Maximum safe speed and maximum safe temperature are shown on fan assembly drawings, catalogs or order acknowledgement.

**Warranty:** The warranty on Chicago Blower fans is our standard warranty. The warranty on the motor is that extended by the motor manufacturer.